

Friday Worksheet
Revision 3

Name:

- 1) The ^1H NMR spectrum of a compound with the chemical formula $\text{C}_3\text{H}_6\text{O}_2$ is shown on the right.

- a) What is the chemical structure of the group of protons that formed the peak at chemical shift 2.0 ppm?

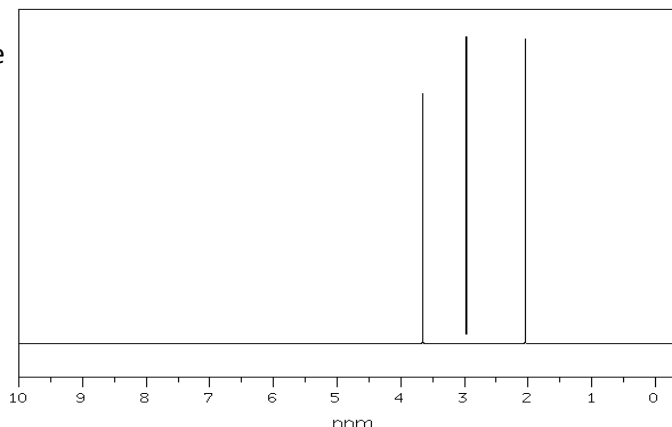

- b) Draw the chemical structure of the compound

- 2) The ^1H NMR spectrum of a compound with the chemical formula $\text{C}_4\text{H}_8\text{O}$ is shown on the right.

- a) What is the likely chemical structure of the group of protons that formed the peak at chemical shift 2.1 ppm?

- b) Draw the chemical structure of the compound

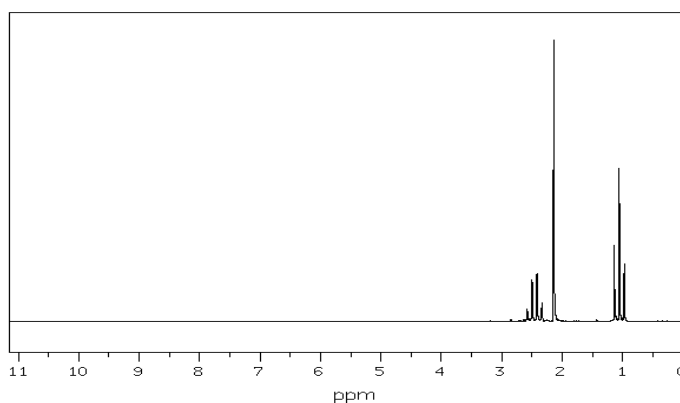

- 3) Aspirin can be made by reacting salicylic acid with acetic acid in the presence of an acid catalyst. The reaction between the phenol group (a hydroxyl group bonded directly to an aromatic reaction) and the acetic acid, however, is slow and has a relatively low yield. When acetic anhydride is used, in place of acetic acid, the reaction is much faster and has a higher yield. The reaction is shown below

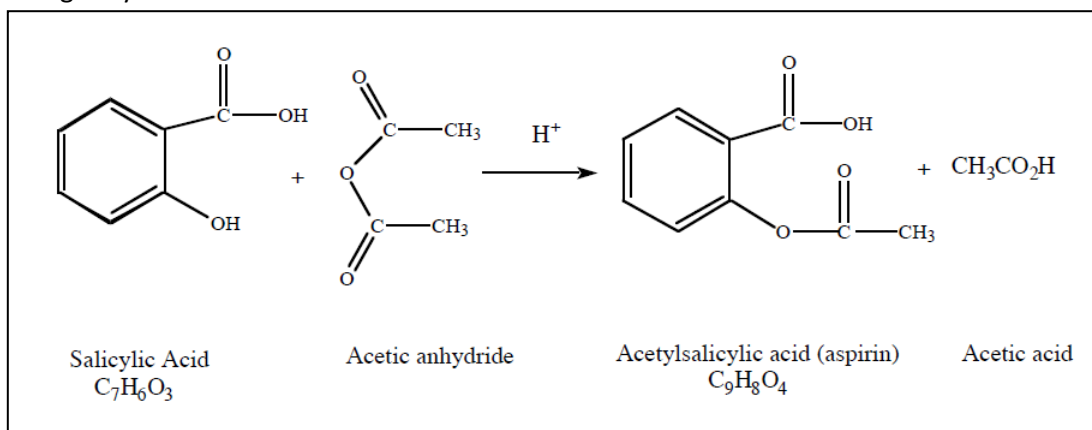

Iron(III) nitrate, $\text{Fe}(\text{NO}_3)_3$ (aq) is used to identify any salicylic acid that has not reacted. The Iron (III) ion reacts with phenols to form a purple complex. Salicylic acid contains a phenol group, but acetylsalicylic acid does not. Therefore, if you add $\text{Fe}(\text{NO}_3)_3$ to an aspirin sample and you see a purple colour, it means that there is still some salicylic acid present and there is incomplete reaction of salicylic acid and acetic anhydride.

- a) i. Write the reaction between salicylic acid and acetic acid in the presence of an acid catalyst.

- ii. What type of reaction is this? Circle the correct response

Acid/Base

Redox

Condensation

Hydrolysis

Explain.

- iii. What functional groups are present in aspirin?

iv. Calculate the percentage yield for the above reaction if the amount of salicylic acid used was 1.89 g and 2.28g of aspirin was obtained.

Molar mass of aspirin 180.16 g/mol molar mass of salicylic acid is 138.12 g/mol

- b) A student was asked to work out the purity of a sample of aspirin derived from the reaction above. Given a sample of the dried aspirin the student decided to dissolve the sample and titrate the resultant solution with NaOH using phenolphthalein as an indicator.

i. Will this method work? Explain

ii. Describe a way that the purity can be tested

- c) A student weighed 2.00 g of salicylic acid. What volume of acetic anhydride is needed to completely react with this amount of salicylic acid if the density of acetic anhydride is 1.082 g/mL. Molar mass of acetic anhydride is 102.1 g/mol

d) A bottle of aspirin was opened by a chemist after several years of been stored on the shelf. The chemist noticed a strong smell of vinegar. When tested with $\text{Fe(III)} (\text{aq})$ ions the solid aspirin turned purple.

i. Write a balanced equation for the reaction that most likely occurred.

ii. What type of reaction took place?

e) A chemist analysed aspirin tablets for quality control. The initial step of the analysis was the standardisation of a NaOH solution. Three 25.00 mL samples of a $0.1014 \text{ mol L}^{-1}$ solution of standardised HCl were titrated with the NaOH solution. The average volume required to reach the endpoint was 25.50 mL.

i. Calculate the concentration of the NaOH solution in mol/Litre.



ii. What is a standard solution?

iii. Why is NaOH not used as a primary standard?

iv Three flasks were prepared each containing a mixture of 20 mL of water and 10 mL of ethanol. An aspirin tablet was dissolved in each flask. The aspirin in each solution was titrated with the standardised NaOH

- Write a balanced equation for the reaction between aspirin and NaOH.

- If the average titre was 16.32 mL find the mass in mg of aspirin in each tablet.

- 4) Ethanol can be used in two ways to generate energy. It can be burnt to release heat or used in a fuel cell to generate electricity.
- a) Ethanol is directly burnt for the purposes of heating and cooking, according to the reaction below

$$\text{CH}_3\text{CH}_2\text{OH}(\text{l}) + 3\text{O}_2(\text{g}) \Rightarrow 2\text{CO}_2(\text{g}) + 3\text{H}_2\text{O}(\text{l}); \Delta H = -1370 \text{ kJ mol}^{-1}$$
 What mass of ethanol is needed to supply 650 MJ of energy, assuming no energy is lost.
 $1 \text{ MJ} = 10^3 \text{ kJ}$
- b) Ethanol may also be used to supply electrical energy. This can be provided by a fuel cell with an acidic electrolyte. The overall cell reaction is identical to the equation given in a) above. In the fuel cell the:
- cathode reaction is,
 - anode reaction is.
- c) If the voltage across the fuel cell is 1.18 V calculate the electrical energy produced by one mole of ethanol.
- d) An alternative way of generating electricity from ethanol is to use it as the fuel to run a generator. Suggest with reasons which is more efficient the fuel cell or the generator.
- 5) The energy content of food can be determined by completely burning a sample of the food in a bomb calorimeter and then calculating the energy released.
- a. The calorimeter to be used contained water and was calibrated by passing an electric current of 1.80 A at 5.70 V for 141 seconds through the heating coil. The temperature of the water rose 1.20 °C.
- Use the data above to calculate the calibration factor, in $\text{kJ } ^\circ\text{C}^{-1}$, for this calorimeter.
 - The carbohydrate, glucose, burns in excess oxygen according to the following equation to produce carbon dioxide and water. Write a balanced chemical equation for the reaction.
 - When a 1.44 g sample of glucose was burned in this calorimeter the temperature of the water increased from 17.22°C to 34.60°C. Calculate the molar heat of combustion of glucose in kJ mol^{-1} .
 Molar mass of glucose = 180.0 g/mol

6) The following diagram represents a $\text{H}^+(\text{aq})/\text{H}_2(\text{g})$ half cell for the reaction

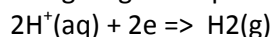

a) For this to be a standard half cell what should be the:

- temperature of the solution
- pH of the solution

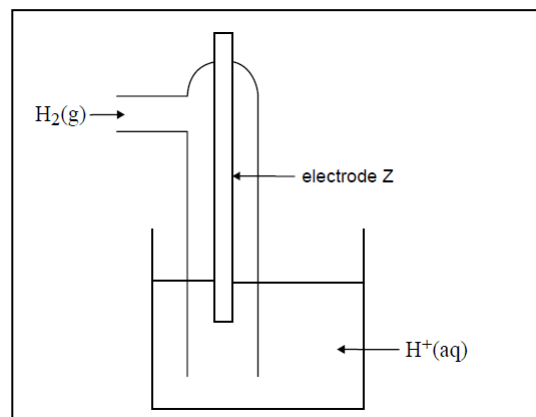

b) A galvanic cell consists of the following half cells which have been set up under standard conditions.

- Half cell 1: the $\text{H}^+(\text{aq})/\text{H}_2(\text{g})$ half cell described in **part a**.
- Half cell 2: a cadmium (Cd) electrode in a solution containing $\text{Cd}^{2+}(\text{aq})$

After some time, the pH in half cell 1 increases.

i. Using this information identify the species in this galvanic cell which is the stronger reductant and explain how you reached this conclusion.

ii. Explain what will happen to the mass of the anode and give a reason.

c) Consider the galvanic cell shown below. After discharging 3860 C of electricity, the concentration of the $\text{X}^{2+}(\text{aq})$ in solution in half cell 1 was found to be 0.600 M. The volume of the solutions in the two half cells had not changed.

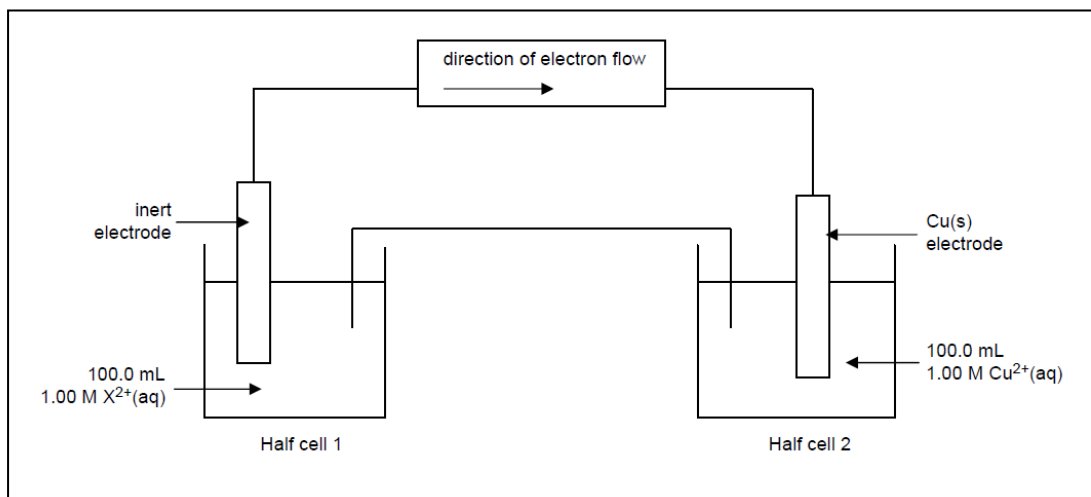

i. Calculate the ratio of mol, of $\text{X}^{2+}(\text{aq})$ that reacted in half cell 1 to the mol of electrons produced.

ii. Give the oxidation reaction occurring in half cell 1

7) A mineral ore contains a mixture of compounds of tin and calcium, in approximately equal proportions. A chemist extracts the metal ions by roasting the ore in air and treating the product with acid. The solution that contains the $\text{Sn}^{4+}(\text{aq})$ and $\text{Ca}^{2+}(\text{aq})$ is then neutralised and placed in an electrolytic cell as shown in the diagram on the right.

- a) Label the anode and cathode of the cell.
b) A reaction occurs at each electrode as the current begins to flow in the cell. Write equations for the half reaction that is likely to occur at the
. positive electrode
. negative electrode

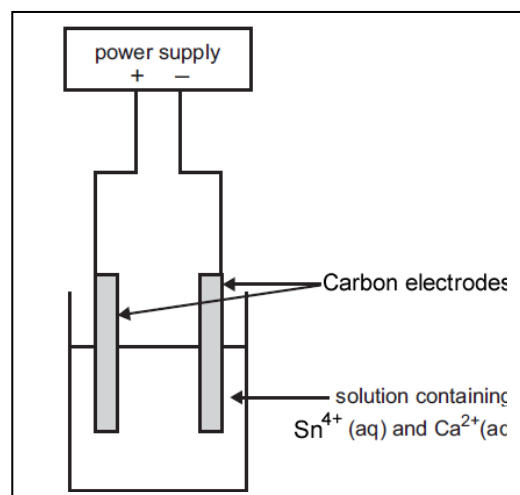

- c) If the chemist had used copper electrodes instead of platinum electrodes, how would this have affected the half reaction at the anode? Explain