

Revision-of alcohols, percentage yield, atom economy, chromatography and spectroscopy

1) Consider the two reactions shown below. They represent reactions that form nitrogen gas.

a) Calculate the percentage atom economy of each reaction.

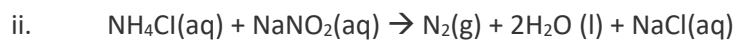
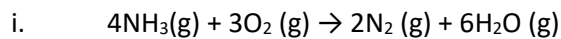

b) Nitrogen gas was produced using equation i. above. Calculate the percentage yield if 3.42 grams of ammonia (NH_3) reacted with excess oxygen to produce 1.40 grams of nitrogen.

2) Consider the reaction pathways shown below.

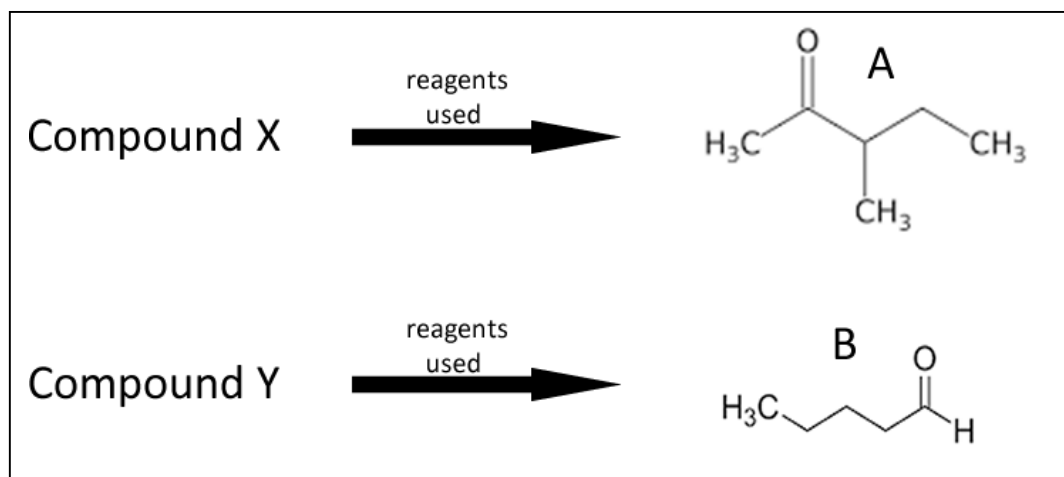

a) Identify the reagents used in each reaction.

b) Name compound X and Y and draw their structural formulae.

c) What type of compound is:

A _____

B _____

- 3) Paper chromatography was used to separate the components of a red food dye used to colour confectionary. Component A is a banned substance.

The chromatogram shown below was produced under the same conditions and is of an unknown red food colouring.

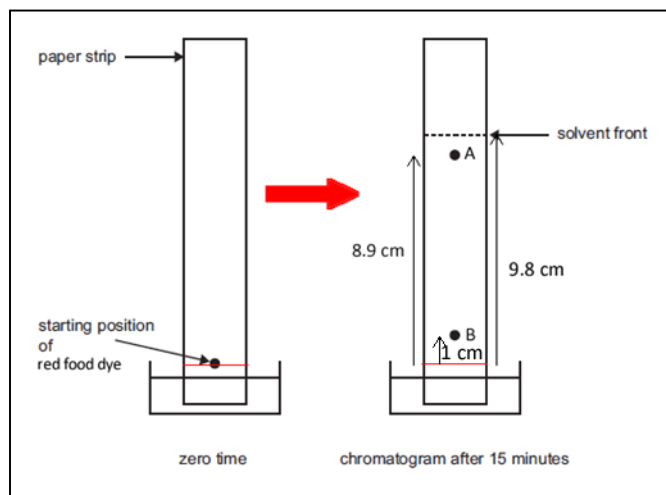

- a) Is component A present in this food colouring? Explain how you arrived at your answer.

- b) Is substance B present in this sample of food dye? Explain.

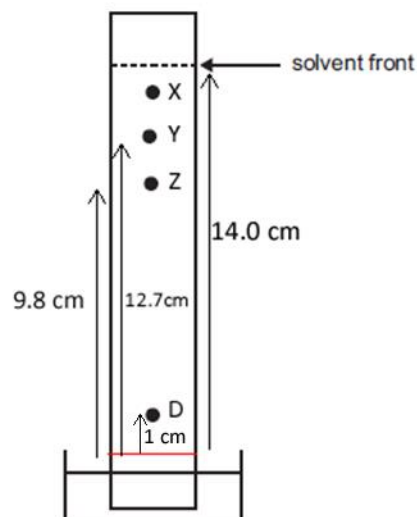

- 4) A mixture of propanoic acid, butan-1-amine and pentane is separated into its components using HPLC. The mixture is dissolved in acetone (CH_3COCH_3) before being placed in the column packed with beads covered with non-polar side chains. The chromatogram shown on the right is produced.

- a) Which molecule represents A, B and C? Explain

- b) Which compound is present in the mixture in the highest concentration?

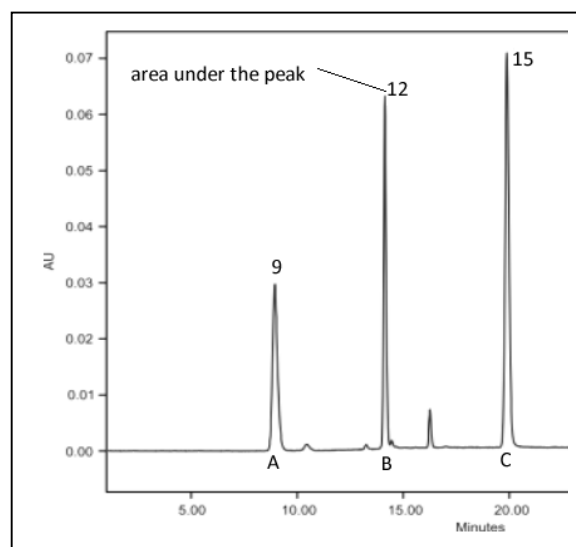

- c) Standard solutions of a pure sample of an unknown compound (X) were analysed using HPLC and the peak area for each sample recorded. This compound had a retention time of 12.0 minutes. The table below shows the data obtained.

Concentration (M)	Area under the peak (relative units)
0.200	2.34
0.400	4.67
0.600	7.02
0.900	10.86

Using the data above, construct a calibration curve .

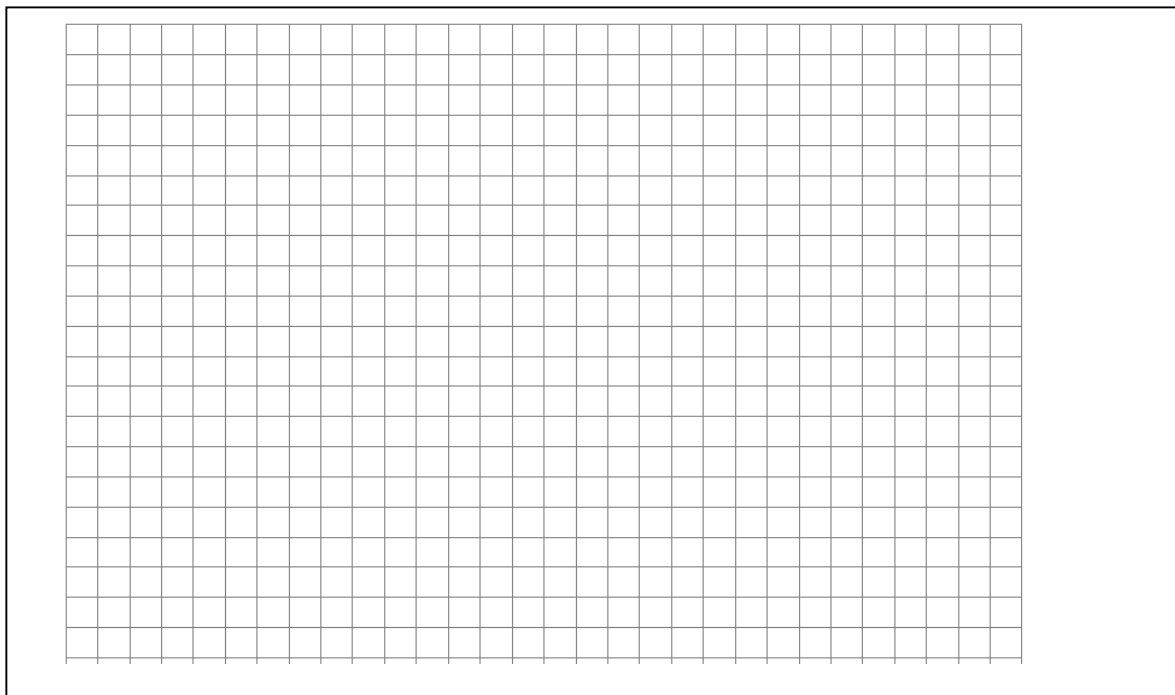

- d) A mixture of different compounds was also analysed using HPLC under the exact conditions as those used in c) above. The chromatogram shown on the right was obtained.

i. Is compound X present?

If so what is its concentration in the mixture?

- e) The same mixture as used in d) above, is placed in the same column under similar conditions except it is now at a higher temperature. How will the chromatogram shown on the right change.
- f) Explain using the words adsorption, and desorption how the separating technique known as HPLC works.

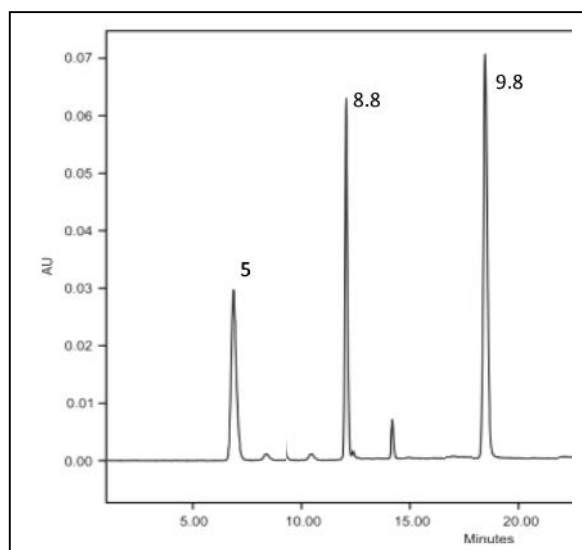

5) A compound with the molecular formula $C_5H_{10}O_2$ was analysed using 1H NMR, IR and mass spectrometry. The spectra are shown on the right.

a) What can be deduced from the IR spectrum.

b) How many non-equivalent hydrogens are present in the molecule.

c) Draw the structural formula of the compound.

d) What fragment is responsible for the base peak in the MS?

e) What fragment is responsible for the peak at 102 m/z ?

